



## ihcDirect® CEA Ab Anti-Human Carcinoembryonic Antigen (Clone C135)

Ab: K31038-015, 150 tissue stains\*

Ab: K31038-005, 50 tissue stains\*

### Intended Use: For *In Vitro* Diagnostic Use

Polymerized horseradish peroxidase (polyHRP)-labeled anti human CEA (Clone C135) antibody is intended for laboratory use to qualitatively identify by light microscopy the presence of CEA molecules which are expressed in many normal cells or tumors in sections of formalin-fixed, paraffin-embedded (FFPE) and/or frozen tissues (FT) using immunohistochemistry (IHC) test method. The clinical interpretation of any staining or its absence should be complemented by morphological studies using proper controls and should be evaluated within the context of the patient's clinical history and other diagnostic tests and proper controls interpreted by a qualified pathologist and/or physician. This conjugate has been pre-diluted and optimized for IHC use without further dilution.

### Summary and Explanation:

The ihcDirect CEA Ab reagent is a polyHRP conjugated mouse monoclonal antibody intended for laboratory use as a qualitative immunohistochemistry reagent for the identification of CEA antigen in both frozen and FFPE tissues. CEA refers to Carcinoembryonic Antigen and is also known as CD66e. It expresses in nearly 100% colorectal cancers (CRC) and is a biomarker commonly used in a colorectal cancer IHC antibody panel. CEA expression is seen in adenocarcinomas from the lung, colon, and stomach. The marker is often used with other markers to help distinguish between adenocarcinoma and epithelioid malignant mesotheliomas.

### Principle of Procedure:

The ready-to-use ihcDirect polyHRP CEA antibody conjugate is directly applied to pretreated tissue sections, where it binds to human CEA. A Working Solution (WS) of a chromogen such as ihc DAB 1:1 is then applied to the tissue. The CEA antibody-linked pHRP reacts with the chromogen to form a visible colored product at the site of the human CEA location. The specimen may then be counterstained and a coverslip applied. Results are viewed and interpreted using a light microscope. Volumes are based upon 100µl antibody per tissue. This reagent may be used to perform IHC manually or on an open automatic IHC staining system. Please read all procedures and Warnings and Precautions sections prior to use.

### Reagents Provided:

Part No.		Description
K31038-015*	150*	15ml of ihcDirect CEA ready-to-use antibody conjugate. See Ancillary Reagents section.
K31038-005*	50*	5ml of ihcDirect CEA ready-to-use antibody conjugate. See Ancillary Reagents section.

\* At estimated volume of 100µl of antibody conjugate per tissue

Immunogen	Clone	Species	Ig Class	Total Protein Conc.
Human CEA	C135	Mouse	IgG	10 mg/ml

CEA antibody is a mouse monoclonal antibody to human CEA purified from animal origin-free cell culture supernatant. HRP is extracted from horseradish plant. Novodiox ihc Blocker and chromogens such as ihc DAB 1:1 Kit, ihc Magenta 1:1 Kit, and DAB Kit are recommended for use with the CEA antibody.

### CEA Antibody (K31038-###):

Reagent Description	Component Part Numbers	Sizes (ml)
CEA pHRP	H31038-(R###) (005, 015)	5, 15

### Ancillary Reagents for Use with CEA Antibody:

Reagent Description	Part Numbers	Sizes (ml)
ihc Blocker Intl. USA	K51001-### (015) (OR)	15
	K51002-### (015, 030)	15, 30
ihc DAB 1:1 Kit	K50002-### (015, 030)	15, 30
ihc Magenta 1:1 Kit USA	K50011-### (015, 030)	15, 30
DAB Kit	K50001-### (015, 030)	15, 30

### Materials Needed but Not Provided:

The following reagents/supplies may be required in staining but are not provided:

- Frozen section fixative (Acetone or 10% NBF§)
  - Positive and negative control tissues
  - Microscope slides, positively charged (required)
  - Staining jars, baths or processing tools
  - ihc Wash Buffer (PBS-T)
  - Pipettor and pipet tips
  - Timer
  - Antigen retrieval buffer (when using FFPE tissues)
  - Peroxide blocker (optional)
  - Instruments used for tissue pretreatment, such as water bath, or pressure cooker or microwave oven (when using FFPE tissues)
  - Hematoxylin
  - Xylene or Xylene substitute
  - Ethanol
  - Mounting medium
  - Cover slips
  - Light microscope (40 - 400x)
- § NBF – neutral buffered formalin

### Novodiox Bulk Reagent Formulations:

- ihc Wash Buffer (PBS-T), (10 mM phosphate buffer, pH 7.2, 150 mM NaCl, 0.05% Tween-20).
- ihc Antigen Retrieval Buffer (10 mM Citric buffer, pH 6.0, 0.02% Tween 20).

### Storage and Handling:

The reagent should be stored at 2-8°C and is suitable for use until expiry date when stored at this temperature. Do not freeze. Do not use the product after expiration date unless dating extension information is provided by Novodiox. If the reagent is stored under any conditions other than those specified in the package insert, they must be verified by the user.

### Specimen Preparation:

**Paraffin Sections:** Tissues routinely processed with 10% NBF are suitable for use prior to paraffin embedding. Consult references (Kiernan, 1981; Sheehan & Hrapchak, 1980). Variable results may occur as a result of prolonged fixation. Each section should be cut to the appropriate thickness (approximately 4-5 µm) and placed on a positively charged glass slide. Slides containing the tissue section may be baked for at least one hour but not exceeding 24 hours in a 58-60°C±5°C oven. Osseous tissues should be decalcified prior to tissue processing to facilitate tissue cutting and prevent damage to microtome blades (Kiernan, 1981; Sheehan & Hrapchak, 1980).

**Frozen Tissue Sections:** Frozen tissue is sectioned to the appropriate thickness (approximately 5 µm) and placed on a positively charged glass slide. Tissues should be fixed in either reagent-grade acetone or 10% NBF for 1-2 minutes immediately after sectioning. Reagent-grade acetone may be kept cold, e.g. at cryostat temperatures or at room temperature. Following fixation, tissues should be processed within a few minutes or may be stored in PBS for as long as a day.



**Treatment of Tissues Prior to Staining:** Pretreatment is tissue dependent and should be performed as suggested in the staining procedure sections.

**Warnings and Precautions:**

1. Read and understand all of the NovodiAx Instructions for Use (IFUs) before product use.
2. The CEA pHRP antibody conjugate is pre-diluted. Further dilution may reduce signal intensity or increase false-negative staining. These recommendations are for guidance only. Laboratory managers should determine their own procedures and quality policies.
3. To obtain best results when working with frozen tissues, it is desirable to freeze tissues as quickly as possible.
4. Use caution and shorten incubation times when utilizing intense hematoxylin counterstains such as Gills as these stains may tend to overstain and obscure antibody staining.
5. Take reasonable precautions when handling reagents. Use protective equipment such as disposable gloves and lab coats when handling suspected carcinogens or toxic materials. Read Safety Data Sheets (SDS) prior to use.
6. Avoid contact of reagents with eyes and mucous membranes. If reagents come in contact with sensitive areas, wash with copious amounts of water.
7. Use charged slides to secure tissues appropriately.
8. Patient specimens and all materials that come into contact with patient specimens should be handled as bio-hazardous materials and disposed of appropriately.
9. Consult local or state authorities with regards to recommended methods of disposal of bio-hazardous and hazardous chemical waste materials.
10. Incubation time and temperature other than those specified may give erroneous results. The user must validate any such changes.
11. Use lab grade quality chemicals such as acetone, ethanol and water when preparing fixatives and buffers. Users should validate performance including stability for laboratory prepared reagents (at 1X).
12. Avoid microbial contamination of reagents.
13. Fixation is a vital part of the protocol and fixation times may vary with the fixative chosen, tissue type, e.g. containing fat and other parameters. Generally, an acetone or NBF fixation of 1-2 minutes is recommended. Place frozen tissue sections into fixation solution shortly after sectioning.
14. **Prolonged exposure to room or freezing temperatures may alter targeted epitopes.** It is best to prevent slides from drying out during the staining process to avoid unwanted background staining.

**Staining Procedures:**

General Operating Notes:

1. Equilibrate all reagents to room temperature prior to use. Swirl or shake the ihc Blocker and pHRP-labeled antibody solutions before use. **Do not vortex.** Calculate the amount of chromogen WS needed (100µl per tissue) and **freshly** prepare chromogen WS. See instructions for use.
2. Gently and thoroughly wash tissues during manual wash steps. Avoid direct high velocity streams of wash that might tend to damage or cut delicate tissues.
3. Following each manual assay step, remove excess fluids on tissue slides with tissue paper. Excessive residual solution may dilute subsequent reagents, causing negative or uneven staining.
4. To reduce background signal, wash thoroughly following antibody step.
5. For the tissues with high level of oxidase activity, e.g. gastrointestinal or renal tissues, an additional blocking step with H<sub>2</sub>O<sub>2</sub> is required to minimize background.
6. The following protocol has been validated at temperatures between 21°-30°C (70°-86°F) for incubating ihc Blocker, CEA pHRP and chromogen WS. If room temperature is less than 21°C, incubate labeled antibody for a longer period of time (≤5 minutes depending upon temperature). Consistent results have been obtained using a slide warmer set to 30°C at the surface of the slide.

**Frozen Tissue Sections:**

1. Following fixation, rinse slides with 1X ihc Wash buffer and then wipe away any excess fluid with a Kimwipe® or paper towel.
2. Dispense 100µl of ihc Blocker, covering the entire tissue, and incubate at room temperature for 1 minute. Then firmly tap off any excess ihc Blocker onto an absorbent surface but do not rinse the slides.

3. Dispense 100µl of pHRP antibody, covering the entire tissue, and incubate for 3 minutes at room temperature. To obtain a darker stain, users may extend incubation up to a total of 5 minutes. Then, rinse slides with 1X ihc Wash buffer and wipe away any excess fluid.
4. Dispense 100µl of a chromogen WS, such as DAB covering the entire tissue, and incubate for 1-3 minutes at room temperature. Users should determine the optimal incubation time for their particular chromogen or lab environment. Then rinse slides with either 1X ihc Wash buffer or lab grade water and wipe away any excess fluid.
5. Add a counterstain. Incubation times will vary according to the counterstain formulation. Then, rinse slides with water and wipe away any excess fluid.
6. Apply aqueous media or dehydrate slides with the user's typical dehydration protocol and then add coverslip.

**Test Timing Est. (10-minute IHC protocol for frozen tissue sections):**

ihcDirect Frozen Tissue Procedure	Time in minutes
Fix with Acetone or Neutral Buffered Formalin	Start
- Wash with <input type="text" value="ihc Wash"/> remove excess fluid	
Block with <input type="text" value="ihc Blocker"/>	1
- Tap+Absorb to remove excess blocker	- - -
NovodiAx ihcDirect pHRP Antibody	3
- Wash thoroughly with <input type="text" value="ihc Wash"/>	
- Tap+Absorb to remove excess wash buffer	- - -
NovodiAx Chromogen Working Solution	1-3
- Wash with <input type="text" value="ihc Wash"/> or DI water	
Hematoxylin counterstain (Conc. Dependent)	2-45 sec
Wash with water	
Dehydrate/Mounting Medium and Coverslip	User Det.
<b>Total</b>	<b>~10</b>

**Paraffin Tissues:**

1. Deparaffinization: Soak slides in Xylene 3 times for 5 minutes each. Next, 3 minutes each in 100%, 95% and 75% ethanol. Then wash slides with tap water in slide tank for two times, 2 minutes each time.
2. Antigen retrieval: Using a water bath, incubate slides in antigen retrieval buffer in a slide tank at 96°C for 30 minutes, then cool the slides down to room temperature for 30 minutes. Rinse the slides twice with tap water, 2 minutes each time.
3. (Optional) Block tissue with H<sub>2</sub>O<sub>2</sub>: Soak the slides in 3% H<sub>2</sub>O<sub>2</sub> in slide tank, stand for 10 minutes. Rinse the slides with tap water twice and then wash once with PBS-T in slide tank for 2 minutes.
4. Dispense 100µl of ihc Blocker covering the entire tissue and incubate at room temperature for 15 minutes. Remove ihc Blocker as much as possible but do not rinse the slides with PBS-T or water.
5. Dispense 100µl of pHRP labeled anti-human CEA antibody on slides covering the entire tissue and incubate for 15-30 minutes at room temperature. Rinse the slides three times with PBS-T in slide tank, 2 minutes each time. Note: Places slides in a wet chamber to prevent evaporation if longer incubation times are used.
6. Dispense 100µl of chromogen WS covering the entire tissue, incubate for 3-10 minutes at room temperature. Rinse the slides twice with tap water in slide tank, 2 minutes each time.
7. Counterstaining: Add hematoxylin and incubate for 1 minute at room temperature. Rinse twice with tap water for 2 minutes, each time.



8. Dehydration: Soak slides in the following order: 75% ethanol for 3 minutes, 95% ethanol for 3 minutes, 100% ethanol for 3 minutes and Xylene twice at 5 minutes each time.
9. Applying Coverslip: Add one drop of permanent mounting medium on both the slide and the coverslip, then apply coverslip.

#### Quality Control Procedures:

Positive and negative controls should be run simultaneously with patient specimens.

**Positive Tissue Control:** The recommended positive control tissues for this antibody are known CEA positive tissues. One positive tissue control for each set of test conditions should be included in each staining run. Previous tissue specimens that have been frozen and freshly cut or in some cases, an individual's own tissue may be used as a control.

The tissues used for the positive control should be selected from patient specimens with well-characterized low levels of the positive target activity that gives weak positive staining. Known positive tissue controls such as colon should only be utilized for monitoring the correct performance of processed tissues and test reagents, rather than as an aid in formulating a specific diagnosis of patient samples. If the positive tissue controls fail to demonstrate positive staining, results with the patient specimens should be considered invalid.

**Negative Tissue Control:** The same tissue used for the positive control may be used as the negative tissue control. The variety of cell types in most tissue sections offers internal negative control sites. But this should be verified by the user. The components that do not stain should demonstrate the absence of specific staining, and provide an indication of non-specific background staining. If specific staining (false positive staining) occurs in the negative tissue control, results with the patient specimens should be considered invalid.

#### Troubleshooting:

If an unexpected staining pattern is observed, consider the following:

1. *No staining:* If no staining is evident on positive control slide, please verify whether (1) chromogen WS was prepared freshly and correctly, (2) reagents were applied in the correct order, (3) pHRP-labeled antibody was indeed added, and (4) for FFPE tissue, dewaxing and antigen retrieval were performed adequately. Perform any corrective actions required and then repeat the procedure.
2. *Low signal or faint staining:* Please check whether (1) the reagents are not expired, (2) temperature of the testing environment was at least 21°C or a 30°C slide warmer was used, (3) chromogen WS was prepared freshly and correctly, (4) excess ihc Wash solution was not left on the slide, causing subsequent reagents to be diluted, and (5) for FFPE tissue, dewaxing and antigen retrieval were performed adequately. Perform any required corrective actions and repeat the procedure. Alternatively, if using a DAB chromogen, consider using another stain, e.g. ihc Magenta 1:1 to obtain more vibrant staining. In addition, some individuals may naturally have low expression of certain antigens. In these cases, users may extend the antibody incubation times by 1-2 minutes.
3. *High background:* Possible causes include (1) insufficient washing, (2) ihc Blocker not being applied or washed out after application, (3) specimens drying out, (4) prolonged chromogen incubation, (5) prolonged pHRP-labeled antibody incubation, and (6) specimens containing high level of endogenous peroxidase, which necessitates an additional blocking step (refer to the Staining Procedures for Paraffin Tissues). Perform any required corrective actions and repeat the procedure.

If an unexpected staining pattern is observed on control tissues or patient samples which cannot be explained by variations in laboratory procedures or a problem with the antibody is suspected, contact Novodiox Technical Support or your local distributor immediately. Within the US and Canada call 1 (888) 439-2716 ext. 2 or 1 (510) 342-3043 ext. 2.

#### Expected Results:

Intense color stains the tissue with a clean background if CEA-expression cells exist. There will be no color staining if no CEA-expression cells exist in the tissue. Interpretation of the staining result is solely the responsibility of the user.











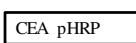

#### General Limitations:

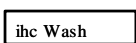
Immunohistochemistry is a multistep diagnostic process that requires specialized training in the selection of the appropriate reagents; tissue selection, fixation, and processing; preparation of the IHC slide; and interpretation of the staining results. Improper fixation, freezing, thawing, washing, drying, heating, sectioning or contamination with other tissues or fluids may produce artifacts, antibody trapping, or false negative results. Inconsistent results may be due to variations in fixation and embedding methods, or to inherent irregularities within the tissue (Nadji M, Morales AR. 1983).

The manufacturer provides these antibodies/reagents at optimal dilution for use following the provided instructions for IHC on prepared tissue sections. Any deviation from recommended test procedures may invalidate declared expected results; appropriate controls must be employed and documented. Users who deviate from recommended test procedures must accept responsibility for interpretation of patient results under these circumstances.

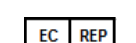
#### Performance Characteristics:

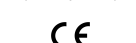
The ihcDirect CEA pHRP test performance has been determined using both frozen and FFPE tissue sections. Novodiox has conducted studies to evaluate the performance of the antibody conjugates and recommended ancillary reagents and supplies. The antibodies and systems have been found to be sensitive and show specific binding to the antigen of interest with minimal to no binding of non-specific tissues or cells. Novodiox antibodies and ancillary reagents have shown reproducible and consistent results when used within a single run, between runs and between lots. These products have been determined to be stable for the periods of time specified on the labels either by standard real-time and/or accelerated methods. Novodiox ensures product quality by testing each lot of material and by testing materials at regular intervals and via surveillance programs.

ihcDirect CEA Key to Symbols			
	<i>In vitro</i> diagnostic medical device		pHRP CEA antibody conjugate
	Catalog Number		Blocking reagent
	Use by: YYYY-MM-DD		ihc Wash Buffer
	Consult Instruction for Use		Manufacturer
	Batch Code		Authorized European Representative
	Contains sufficient for < n > tests		CE Mark
	Temperature Limitation		

#### Instructions for Use (IFU) Access:

To obtain a translation or the latest electronic version of an IFU document, visit our website at <https://www.novodiox.com/literature/instructions-for-use-ifu/>. Printed copies of an IFU document may be obtained by contacting Novodiox Technical Support or your local distributor.

#### Bibliography:

1. Kiernan JA. Histological and Histochemical Methods: Theory and Practice. New York: Pergamon Press 1981.
2. Sheehan DC and Hrapchak BB. Theory and Practice of Histotechnology. St. Louis: C.V.Mosby Co. 1980.
3. Nadji M, Morales AR. Immunoperoxidase, part I: the techniques and its pitfalls. Lab Med,1983;14:767-771.
4. Berretta M, Alessandrini L, et al. Serum and tissue markers in colorectal cancer: State of art. Critical Reviews in Oncology/Hematology. 2017; 111:103-116.
5. Tiernan JP, Perry SL, et al. Carcinoembryonic antigen is the preferred biomarker for in vivo colorectal cancer targeting. Br J Cancer. 2013 Feb 19; 108 (3):662-667.
6. Wu K-L, Huang E-Y, et al. Synergistic interaction between galectin-3 and carcinoembryonic antigen promotes colorectal cancer metastasis. Oncotarget. 2017; Vol. 8, No. 37: 61935-61943.

